

Introduction



FHS300 is based on the original imported FPGA integrated circuit from America's Intel corporation. Its algorithm belongs to combination of threshold comparison gate circuit delay method and high-speed ADC correlation method. The main advantage is reflected in clamp-on ultrasonic flow meter. It is different from other 99% domestic clamp-on ultrasonic flow meters which are using the outdated capacitor charging algorithm or using algorithm of either comparison or correlation alone. So, our FHS300 belongs to high-end transit-time ultrasonic flow meter. Its measuring frequency can be more than 300 times per second (domestic other 99% clamp-on ultrasonic flow meters are less than 50 times per second, or even just once per second). Its accuracy is strictly controlled to be better than 1.0%. Moreover, its tolerance rate to bubbles in the measured pipe has been greatly improved, and the maximum tolerance time for continuous bubbles or impurities is 5 seconds.

Concise and high-end patent appearance design;
 Innovative design of covers hides all screws after installation;
 4 lines of LCD screen are clearer and broader than other 2 lines of segment code screen;
 membrane keyboard offers longer service life and more comfortable hand feeling.



Sensor glue



Transducer TT01



Transducer TT03

Clamp-on flow transducers adopt imported sealant and sealed by adhesive inside.
 Integrated production of transducers and signal cables make it true IP68 waterproof rating.
 Acoustic wedge material-the key measuring part of the transducer is imported from Germany. Matching degree between each pair of transducers is ≤ 2 nanoseconds.
 One pair of transducers can be used for DN25-DN1200mm wide pipe range measurement.
 Maximum signal cable length can be extended to as long as 300m.
 Innovative hidden design of clamp straps area is attractive and practical.

1.0 Clamp-on type

Specification

Performance	
Flow range	±0.09ft/s ~ ±39ft/s (±0.03m/s ~ ±12m/s)
Accuracy	±1% of measured value
Repeatability	0.2% of measured value
Linearity	±1%
Pipe size	DN25mm~DN1200mm(A pair of sensors)
Function	
Outputs	Analog output: 4~20mA, max load 750Ω. Pulse output: 0~10KHz
Communication	RS232/RS485 Modbus
Power supply	10~36VDC/AC90~245V
Display	240*128 backlit LCD
Temperature	Transmitter: -14°F~140°F(-20°C~60°C) Transducer: -40°F~176°F(-40°C~80°C,TT01) Transducer: -40°F~266°F(-40°C~130°C,TT03) Transducer: -40°F~356°F(-40°C~180°C,TT02H)
Humidity	Up to 99% RH,non-condensing
Physical	
Transmitter	PC+ABS,IP65
Transducer	Encapsulated design,IP68 Double-shielded transducer cable Standard/maximum cable length:30ft/1000ft(9m/300m)

Product size

Transmitter size

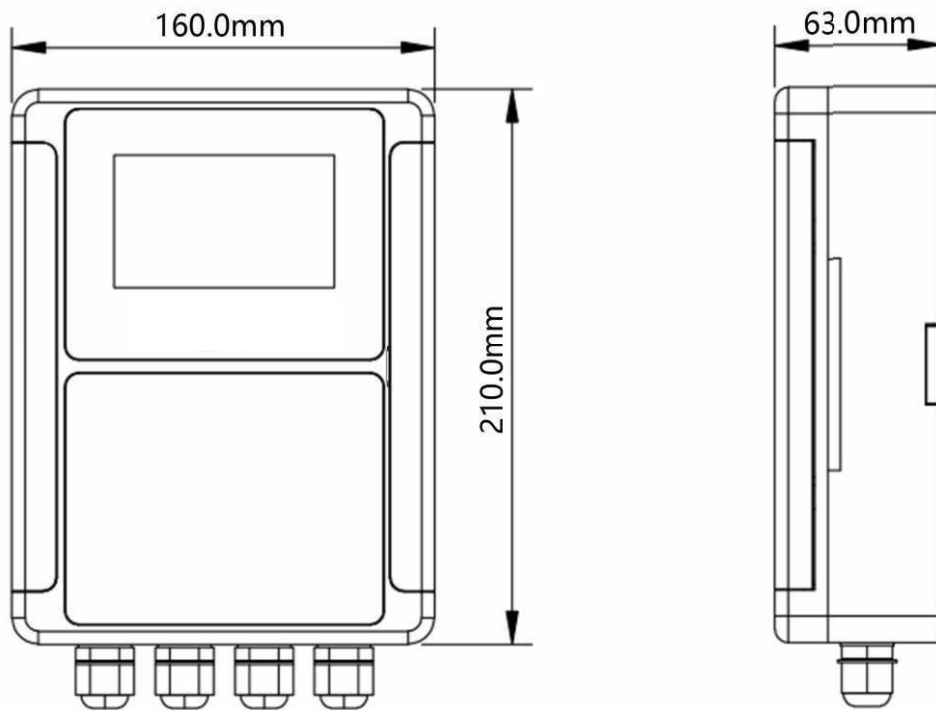

Transducer size

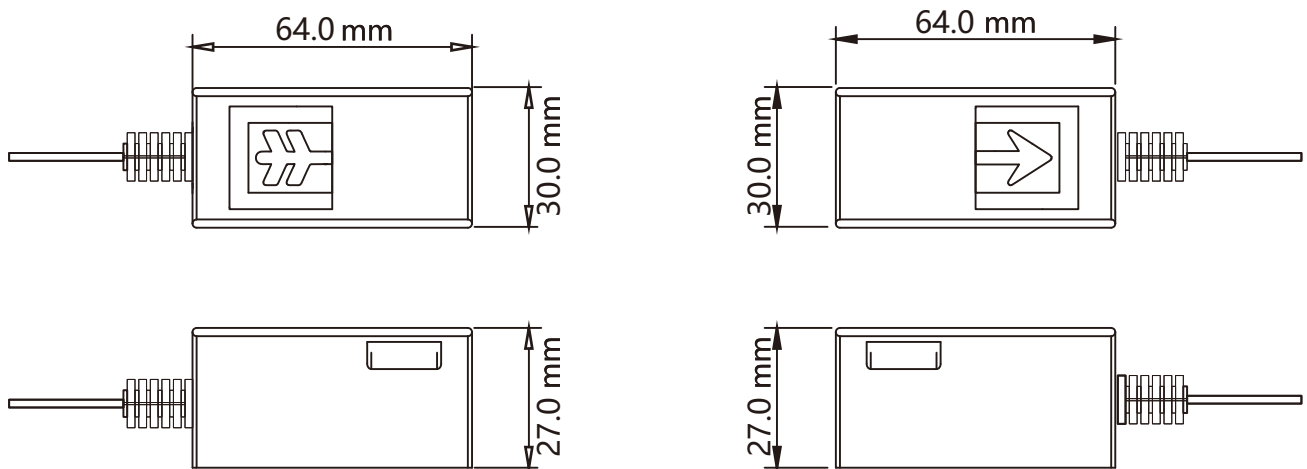

1.0 Clamp-on type

Configuration diagram



1.0 Clamp-on type

Product weight



Transmitter weight:
0.96kg



Transducer weight:
1.0kg



Gross weight:
3.11kg

Installation requirement

Choose a section of pipe that is always full of liquid, such as a pipe flowing vertically upward or horizontally. Ensure that the surface temperature of the pipeline at the measuring point is under the transducers' temperature limits. Consider the inside condition of the pipe carefully. If possible: select a section of pipe that is free from excessive corrosion or scaling. Ensure enough straight pipe length at least equal to the figure shown below for the upstream and downstream transducers installation.

mounting point	straight pipe length before upstream transducer	straight pipe length after downstream transducer
90° bend		
Tee		
Expanding pipe		
Reducing pipe		
Valve		
Pump		

1.0 Clamp-on type

Ordering confirmation

Model	Transmitter
FHS300	Ultrasonic flowmeter Wall mount Flow range: $\pm 0.09\text{ft/s} \sim \pm 39\text{ft/s}$ ($\pm 0.03\text{m/s} \sim \pm 12\text{m/s}$) Accuracy : $\pm 1\%$ of the measure value Repeatability: 0.2% of the measure value Display: 240*128 backlit LCD Power supply: 10~36VDC/AC90~245V Transmitter enclosure: IP65, ABS (Temperature: -20°C~50°C) Output: OCT pulse output 0-10KHz, Relay output, 4-20mA optional Communication: RS232, Modbus Protocol
Code	Output
1	OCT, Relay, RS232/RS485, 4-20mA,
2	OCT Relay, RS232/RS485, 4-20mA RTD
Code	Transducer
TT01	Clamp-on, IP68. Operating temperature: -40 °F ~ +176 °F(-40°C ~ +80 °C)
TT03	Clamp-on, IP68. Operating temperature: -40 °F ~ +266°F(-40°C ~ +130 °C)
TT02H	Clamp-on, IP68. Operating temperature: -40 °F ~ +356 °F(-40°C ~ +180 °C)
XXX	Transducer cable length
030	Standard length 30ft (9m)
XXX	Max length to 1000ft (300m)
Code	Temperature sensor
PT1000	Pt1000 temperature sensor+RTD module(selection)
Code	Memory
SD	SD card(8G)+ SD card module(selection)

Standard model: FHS300- 1 - TT01 - 030

Description: Standard ensure clamp-on type ultrasonic flowmeter, OCT, Relay, RS485, 4-20mA, 30ft cable.

Pictures for optional transducers



Clamp-on ultrasonic flowmeter: FHS300-TT01
(Applicable temp.: -40°C ~ +80°C)



(Applicable temp.: -40°C ~ +130°C)



Insertion ultrasonic cold/heat flowmeter :
FHS300-TT05-PT1000

