

SEM5086 Compact Meteorological Station

MAIN FEATURES

- Miniaturization design
- High integration, all-in-one
- Modular, no moving parts
- Special process heat insulation treatment of protective cover
- Support extended parameter

APPLICATION

- Meteorological monitoring
- Micro environmental monitoring
- Grid environment monitoring
- Agrometeorological monitoring
- Traffic meteorological monitoring
- PV environmental monitoring



OVERVIEW

SEM5086 is a compact meteorological station, that is, the product parameters include atmospheric temperature, humidity, wind speed, wind direction, air pressure, PM2.5, PM10 and noise. Through a highly integrated structure, it can realize 24-hour continuous online monitoring of outdoor meteorological parameters, and output eight parameters to users at one time through the digital communication interface.

SPECIFICATION

ITEMS	Range	Accuracy	Resolution	Sampling frequency
Wind speed	0-60m /s	$\pm(0.3+0.03V)$ m/s; $V \leq 30$ m/s $\pm(0.3+0.05V)$ m/s; $V \geq 30$ m/s (V=wind tunnel standard wind speed value)	0.01m/s	4Hz
Wind direction	0-359.5°	$\pm 3^\circ$ (when wind speed < 10m/s)	0.1°	4Hz
Air temperature	- 40 °C - + 85 °C	$\pm 0.3^\circ\text{C}@25^\circ\text{C}$	0.01 °C	1Hz
Air Humidity	0-100%RH	$\pm 3\%$ RH (10% - 80% RH, no condensation)	0.01%RH	1Hz
Atmospheric pressure	500 -1100hPa	± 0.5 hPa (25°C, 950-1100hPa)	0.1hPa	1Hz
Noise	30-130dB	± 1.5 dB	0.1dB	1Hz
PM2.5	0-500ug/m ³ (expandable 1000ug/m ³)	$\pm (10+10\%)$ ug/m ³	1ug/m ³	1Hz
PM10	0-500ug/m ³ (expandable 1000ug/m ³)	$\pm (10+10\%)$ ug/m ³	1ug/m ³	1Hz
Working temperature	-40°C~80°C			
Output signal	Default RS485 interface, ModbusRTU; Customizable SDI-12			
Max. output frequency	Passive mode: 1/S Active mode: 1/min			
Power supply	DC9-24V			
Protection level	IP65			
Fixing method	Default fixed by sleeve (Flange fixing or bending plate fixing optional)			
Fixing bracket	None for standard products, 1.5m and 1.8m brackets are optional			
Cable	Default 3m cable (other length optional)			
Customized functions	Tilt angle/electronic compass, heating function, GPS positioning			

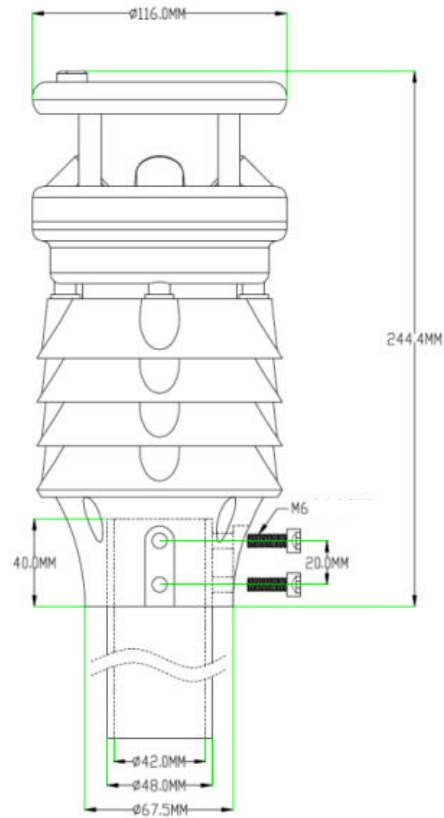
DIMENSION



INSTALLATION

- Fixing method of bending plate:

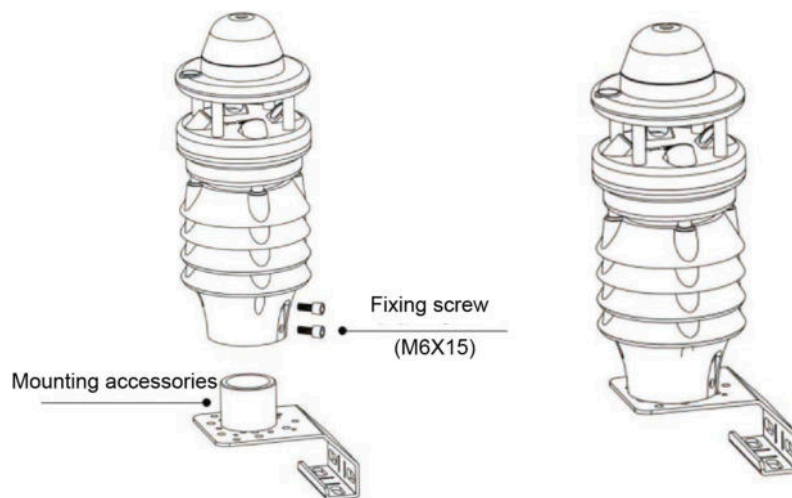

- Fixing method of flange plate:

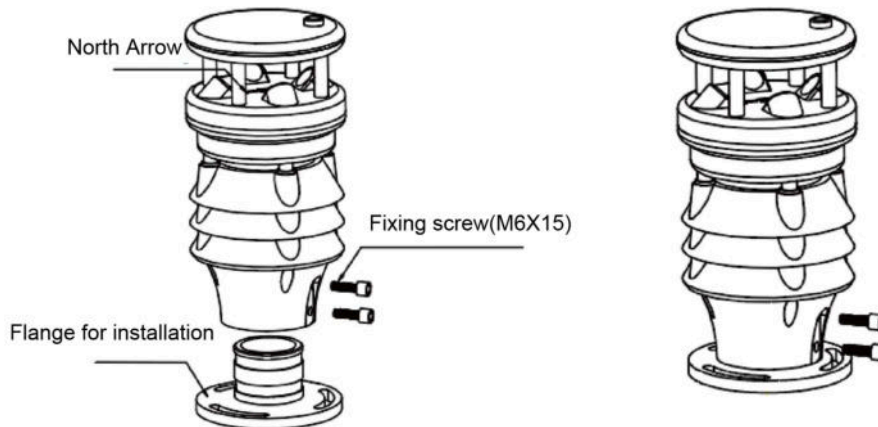

ORDER CODE

Name	Compact Weather Station	
Model	Code	Function
	SEM5086	Wind speed+wind direction+Temperature +humidity+Atmospheric pressure +Noise+PM2.5+PM10

Note:

1. The sensor with integrated atmospheric temperature, humidity and pressure parameters is installed in a three-layer outdoor radiation shield, which is configured with special proportion of PC+fiber, and the internal thermal insulation layer is sprayed to minimize the impact of solar radiation. No moving parts, ensuring the accuracy of long-term measurement data.
2. Two parameters of wind speed and direction: measure the wind speed and direction through ultrasonic principle, and output the instantaneous wind speed, instantaneous wind direction, average wind speed, average wind direction and other data. The optional electronic compass is used to measure the apparent wind speed and direction data, and the GPS is used to calculate the real wind speed and direction.
2. Noise: High precision electret pickup is selected to measure the environmental noise by A-weighting method. It has the characteristics of small volume, high precision and high sensitivity.
3. PM2.5/PM10 particles: Based on the principle of laser scattering, the number of suspended particles with different diameters in the air per unit volume can be continuously collected and calculated, that is, the particle concentration distribution.